

E2T CONTROL UNIT ECONOMISER 4÷16 OUTPUT CHANNELS



DESCRIPTION

Economiser for controlling the pneumatic cleaning of industrial dust collector systems. It has 2 output relay contacts and 2 digital input contacts. Differential pressure digital control through internal transducer, which allows the accurate analysis of the filter clogging status. 3-digit luminous LED display, which allows to read the filter clogging status, the active solenoid valves and any alarms, at all times.

OPTIONS UPON REQUEST

- Activation of 2 solenoid valves for every output channel.
- Cable glands for power supply input and output of solenoid valves drive cables.
- Connector from wired panel for connection to Matrix cabling.
- Built-in pilots for remote control of the pneumatic valves.
- Casing container with different format.
- Zone 22 ATEX Certification.

REFERENCE STANDARDS

- Directive 2014/30/EC Electromagnetic Compatibility meeting European harmonised standards EN61000-6-2:2005 class B in standard EN61000-6-4:2001
- Directive 2014/35/EU Low Voltage meeting European harmonised standards EN 60947-1:2004

For additional information and technical specifications, consult www.turbocontrols.eu

TECHNICAL SPECIFICATIONS

Power supply voltage	115 Vac 50-60 Hz \pm 10 % 230 Vac 50-60 Hz \pm 10 %
Power supply voltage upon request	24 Vac \pm 10 % 24 Vdc \pm 10 %
Output voltage for solenoid valves	115 Vac 50-60 Hz 230 Vac 50-60 Hz 24 Vac 24 Vdc
Inputs	Remote enabling consent switch. Post-cleaning cycles fan switch.
Solenoid valves output channels	4 ÷ 16
Active output 4-20ma	Proportional to the dP reading for remote consultation of the pressure.
Electric consumption	28 Watts at maximum load
Alarm Relays	2 normally closed Maximum load: 3A @ 250Vac, 2A @ 24Vdc, 24 Vac.
Differential pressure switch	0 - 4 kPa
Screen	3 x 0.8 inch digit 7-segment LED display
5 x 20 mm glass fuse	115 or 230 Vac 1 x 1 A 24 Vac or 24 Vdc 1 x 3 A
Operating temperature	-10 °C - 55 °C
Storage temperature	-20 °C - 60 °C
Environmental humidity	0 ÷ 95% Relative non condensing
Valves opening impulse time	50 m.sec. ÷ 5 sec.
Interval pause time between valves opening	1 sec. ÷ 999 sec.
Casing	Base in ABS Lid in Polycarbonate
Protection rating from water and dust	IP65 DIN EN 60529
Shock resistance	IK07 2 Joule (EN62262)

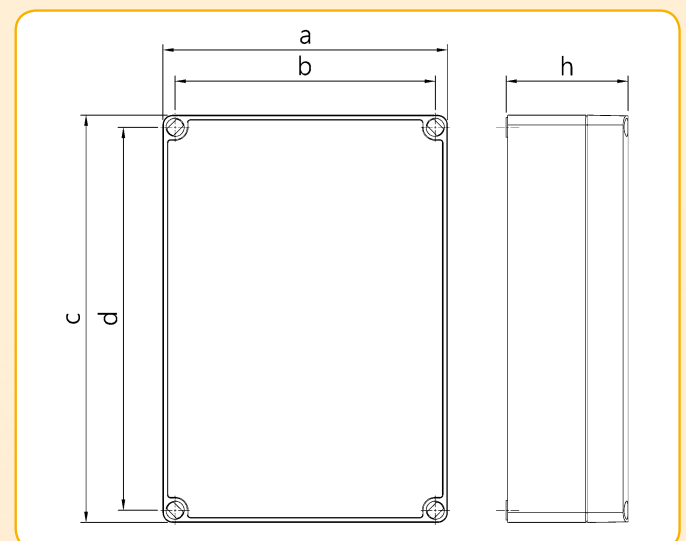

	Number of output channels		Dimension of the Structure				
	a	b	c	d	h		
4 ÷ 8	175	160	175	160	75		
12 ÷ 16	175	160	250	235	75		